

JVC

SERVICE MANUAL

MODEL

L-A55

DIRECT DRIVE
AUTO-RETURN
TURNTABLE

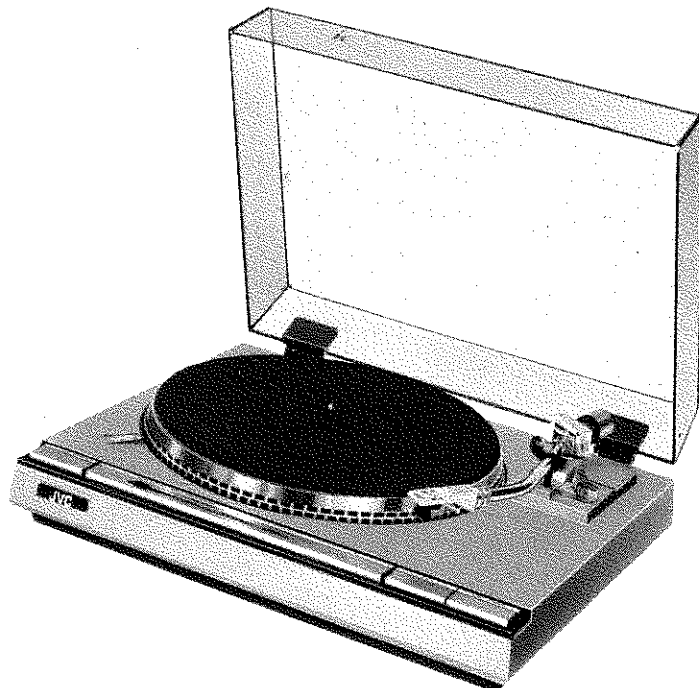

Contents

	Page
1. Specifications	2
2. Service Precautions	2
3. Features	2
4. "How to Operate" (Names and Functions).	3
5. Operation of Automatic Mechanism	4
6. Block Diagrams	
Servomotor Control System	5
7. Mounting Cartridge	5
8. Adjustment Procedures	
Tonearm Section	
8-(1) Overhang Adjustment	6
8-(2) Anti-skating Adjustment	6
8-(3) Tonearm Lifter Height Adjustment.	6
8-(4) Headshell Mounting Angle Adjustment	6
8-(5) Tracking Force Adjustment.	7
8-(6) Auto-return (Lead-out) Adjustment	7
Servomotor Control Section	
8-(7) Speed Adjustment	7
9. Troubleshooting	
9-(1) Chart 1. Platter does not rotate	8
9-(2) Chart 2. Platter rotates at a high speed.	9
10. Lubrication	10
11. Exploded Views and Parts List	
11-(1) Tonearm Assembly	10
11-(2) Cabinet and Mechanism Assembly and Parts List	11
11-(3) Parts List with Specified number for Designated Areas	13
12. L-A55 Schematic Diagram.	14
13. Printed Circuit Board Ass'y	15
14. Connection Diagram of TPS-246	20
15. Packing Materials and Part Number	21
16. Accessories List.	21
17. Power Specification	24

WARNING!

When replacing the parts marked with , be sure to use the designated parts to ensure safety.

CHECKING YOUR LINE VOLTAGE (For U.S. Military Market and Other Countries)

Before inserting the power plug, please check this setting to see that it corresponds with the line voltage in your area. If it doesn't, be sure to adjust the voltage selector switch to the proper setting before operating this equipment. The voltage selector switch is located either on the set's on the chassis. Simply insert a screw driver into the voltage selector switch and turn it in either direction while pressing slightly and in such a way that desired voltage marked on the switch is positioned the arrow marked on the rear panel or the chassis. The voltage selector switch accommodates up to three turns in either direction.

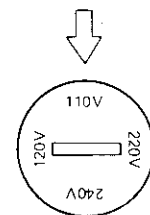

1. Specifications

Motor section

Motor	: Coreless, DC type FG servomotor
Drive system	: Direct drive
Speeds	: 33-1/3 and 45 rpm
Pitch control range	: $\pm 3\%$
Wow and flutter	: Less than 0.03% (WRMS), 0.015% (WRMS)* 0.045% (DIN)
Rumble	: More than 75 dB (DIN-B)
Speed detection	: Integrated frequency generator
Platter	: 30.8 cm diameter

Tonearm section

Type	: T.H. (Tracing-Hold system, static balance) S-shaped tubular arm
Effective length	: 220 mm
Tracking error	: $+3^{\circ}35' -0^{\circ}43'$
Overhang	: 15 mm
Tracking force range	: 0 — 3 g (0.1 grams division, direct reading)
Weight range (including headshell)	: 12.5 ~ 18.5 g

Cartridge section (not provided on units for U.S.A., Canada and the U.K.)

MODEL	: Z-1S
Type	: Moving Magnet (Cartridge body: MD-1025)
Stylus	: 0.6 mil. diamond (DT-Z1S)
Optimum tracking force	: 1.75 ± 0.25 grams
Output	: 3 mV (1kHz, 5 cm/sec)
Frequency response	: 10 to 25,000 Hz
Separation	: More than 25 dB (1 kHz) (with test record TRS-1)
Load resistance	: 47 kilohms — 100 kilohms
Compliance	: 10×10^{-6} cm/dyne (Dynamic) 30×10^{-6} cm/dyne (Static)

General

Dimensions	: 13.1(H) x 43.8(W) x 38(D) cm (with cover closed) (5-5/32" x 17-1/4" x 14-31/32") (Since the dimensions show only the design measurements, consideration is required when installing the unit in a limited space such as a rack.)
Weight	: 5.5 kg (12.1 lbs.) (without corrugated cardboard case)

* Measured at attached encoder's output by K & K measuring method.

2. Service Precautions

1. Be sure to place the unit on a level surface when adjusting motor rotation.
2. In servicing, do not use parts other than those specified.
3. Be careful not to damage the motor shaft when repairing the motor unit.
4. When the heat sink (including X601) and the other small circuit board are removed from the motor board to permit repair of the circuit board, the transistor temperature may increase due to the lack of heat radiation.

3. Features

- DC type FG servomotor
- Direct Drive tow-row stroboscope
- Oil-damaged cueing
- Anti-skating mechanism
- All front operations.

4. "How to Operate" (Names and Functions)

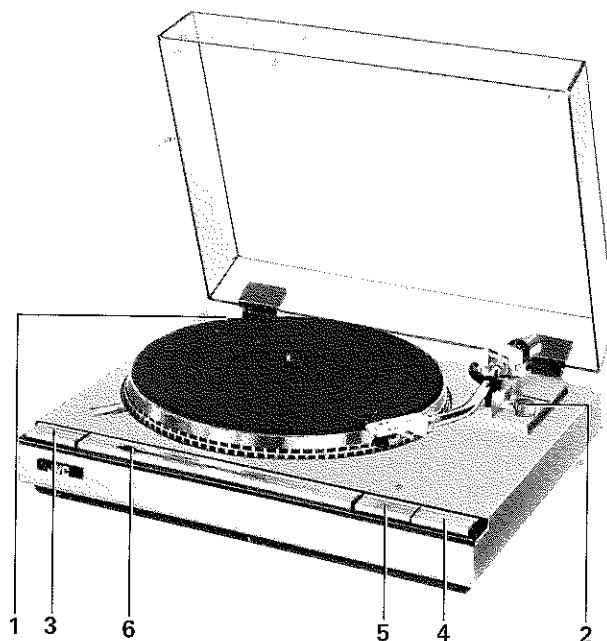

Fig. 1

1. EP adaptor

Place this adaptor onto the center spindle when you play a record with a bigger center hole such as a doughnut record.

2. Anti-skating knob

This device cancels out the centripetal force that pulls the tonearm to the center of the platter. This prevents the stylus tip from skating toward the center of the platter and at the same time eliminates any excessive stylus tip force on the inner wall of the record groove.

Use the ● marked dial when employing a spherical stylus. Use the ● marked dial when employing an elliptical stylus or a Shibata stylus.

Turn the dial to the same number as the tracking force dial.

3. Speed select button

Select a proper position (33 or 45) of the speed select button in accordance with the rpm of the record.

33-1/3 rpm record (LP) "33"

45 rpm record (EP) "45"

4. Arm lifter button

This is used when you want the tonearm gently lifted up to lowered down. When you push it to "UP" position () the tonearm will be lifted up, and when you push it to "DOWN" position () it will be lowered down gently onto the record surface.

5. Reject button

When you stop playing the record, push the button and release it. The button returns to its original position and the tonearm lifts itself up, returns automatically to its rest and the platter stops rotating.

6. Pitch control knob and strobo disc



Strobe pattern and stroboscope

When speed adjustment is performed, observe the strobe pattern around the periphery of the platter for 33-1/3 disc and use the stroboscope provided for 45 speed.

Turn the speed adjustment knob until the dots appear to be stationary.

Be sure to use the dot pattern corresponding to the local line frequency.

- The dots appear to move in the same direction as the platter.

Turntable rpm is too fast.

Turn the speed adjustment knob toward S (slow).

- The dots appear to move in the direction opposite to the platter.

Turntable rpm is too slow.

Turn the speed adjustment knob toward F (fast).

- The dots appear to be stationary.

Turntable rpm is proper.

Your new L-A55 is designed to constantly maintain the correct speed, once the fine pitch adjustment has been made despite fluctuations in the AC mains voltage and frequency (normally $\pm 0.4\%$ on average) which may cause slight changes in the strobe patterns due to lighting of the neon lamp, and speed adjustment is not required.

5. Operation of Automatic Mechanism

Change cycle mechanism:

1. During playing, the notch of the main gear position relative to the turntable spindle gear is as shown in Fig. 2.
2. As the projection is away from the engagement, the main gear does not rotate even though the turntable.
3. As playing proceeds, the trip slide moves toward the center of the turntable following the movement of the tonearm as shown in Fig. 3.
4. The engagement is very easy to move as it simply rests on the lower trip. On the music section of the record groove the engagement moves so slightly that it is returned by the tip of the projection. Consequently, the turntable spindle gear does not engage with the main gear and thus does not trigger the auto-return operation.
5. When playing ends and the pick-up cartridge enters the lead-out groove which is spaced out, the engagement advances more than it is returned by the projection. Because of this, the engagement is pressed by the projection as shown in Fig. 4, causing the main gear to turn and engage with the turntable spindle gear. Thus the change cycle is started.

This completes the automatic cycle.

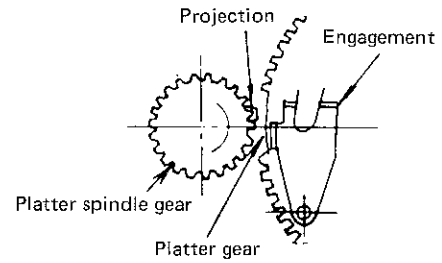

Fig. 2

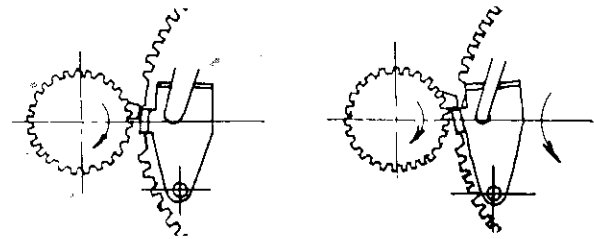

Fig. 3

Fig. 4

Tonearm lift and return mechanism:

1. When the main gear starts to rotate at the end of playing, the return lever rotates under the action of the main gear cam to press the elevator cam. The upward movement of the elevator cam is directly converted into movement of the elevator, lifting up the tonearm. (Fig. 5)
2. The tonearm is returned by the arm lever the end of which presses it as the main gear rotates. (Fig. 6)

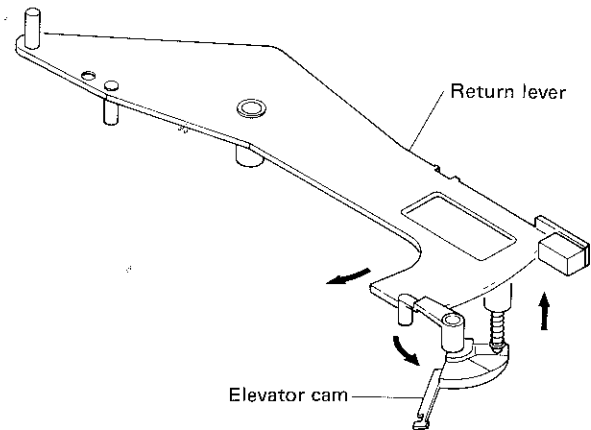

Fig. 5

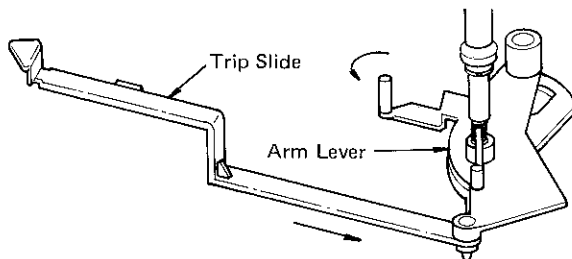

Fig. 6

6. Block Diagrams

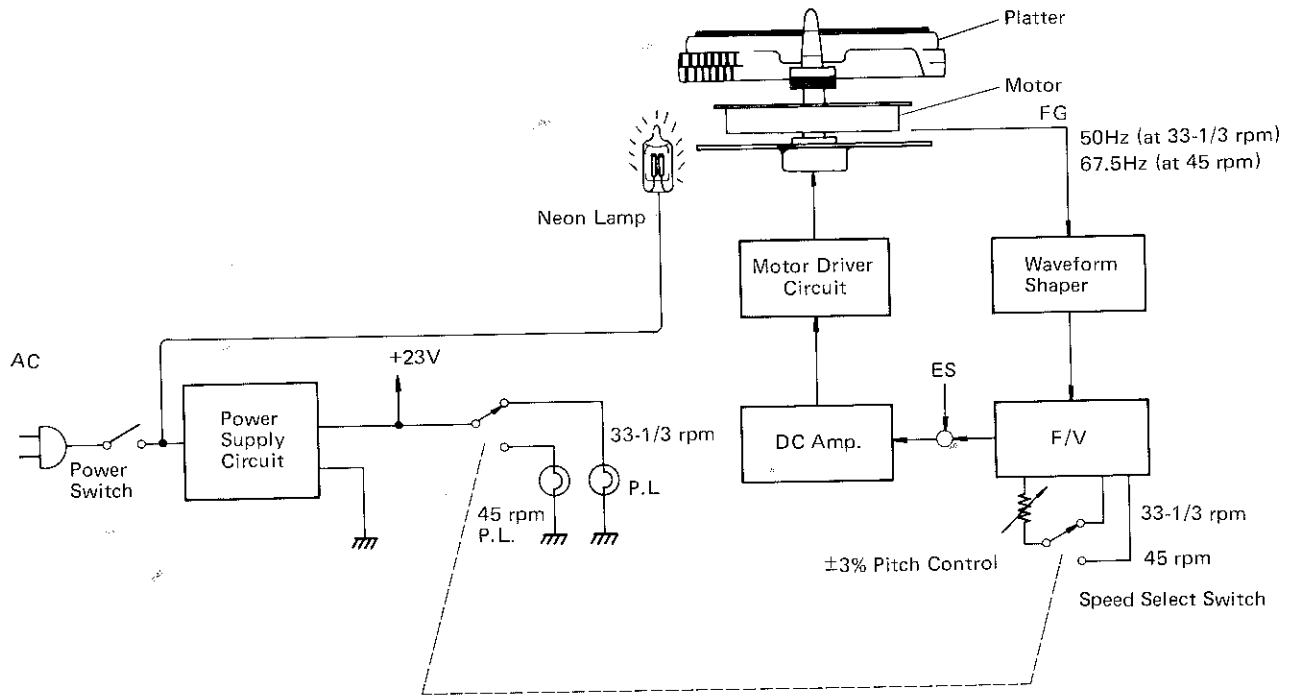

Fig. 7

7. Mounting Cartridge

- Removal and mounting of the headshell (Fig. 8)**
 Turn the connector nut in the direction of "A" to remove the headshell from the tonearm. Turn it in the direction of "B" for mounting the headshell.
- Mounting cartridge (Fig. 9)**
 - Remove the 2 screws securing the cartridge on the headshell.
 - Install your cartridge onto the headshell provided or onto a headshell of your selection.
 - The four headshell lead wires are colour-coded as follows, connect them correctly:

White(+)L	Red(+)R
Blue(-)LE	Green(-)RE
	(Left)		(Right)
 - Mount the cartridge properly onto the headshell and leave the set screws slightly loosened, then, after completing the "overhang adjustment" (see P. 6) tighten them firmly.
 - After each cartridge replacement, be sure to perform "tracking force" (see P. 7) and "anti-skating" (see P. 6) adjustments.

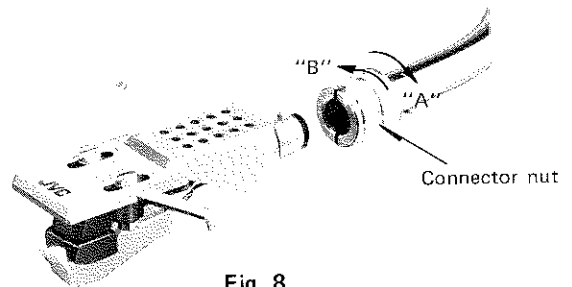

Fig. 8

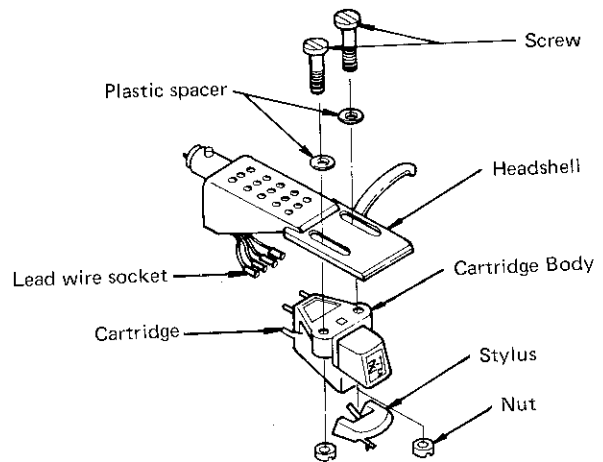

Fig. 9

8. Adjustment Procedures

Tonearm Section

Adjustment

The following adjustments should be performed only when replacing a cartridge or a headshell.

Otherwise, no adjustment is required.

Note: If necessary to replace a cartridge, usage of that headshell exclusive to this unit is recommended.

8-(1) Overhang Adjustment

To obtain optimum overhang, when mounting the cartridge, first align the cartridge's longitudinal axis to that of the headshell and position the cartridge so that the distance between the headshell's end face and the stylus tip equals 48 mm as shown in Fig. 10.

Be sure to tighten the set screw after the adjustment. Errors within 1 mm are negligible from a practical point of view.

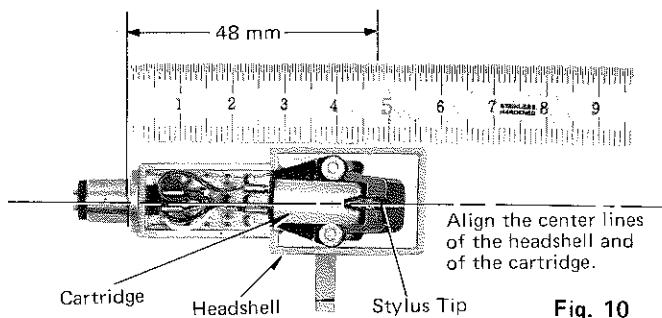

Fig. 10

8-(2) Anti-skating Adjustment

Adjust the anti-skating force according to the cartridge used. Turn the anti-skating knob dial to the same number on the tracking force dial.

Use the ● marked dial when employing a spherical stylus. Use the ● marked dial for an elliptical or a Shibata stylus. Set the "1.75" of the ● marked dial to the index line since the L-A55 is provided with a spherical stylus and the tracking force has been adjusted to 1.75 g. (Fig. 11)

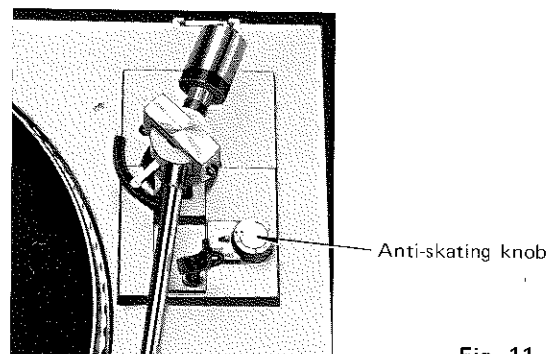

Fig. 11

8-(3) Tonearm Lifter Height Adjustment

Adjust the height of tonearm lifter with the adjustment screw so that the distance between the stylus tip and the surface of record is about 6 mm when the stylus is elevated. Turn the height adjustment screw clockwise to lower, and counterclockwise to raise the tonearm lifter level. (Fig. 12)

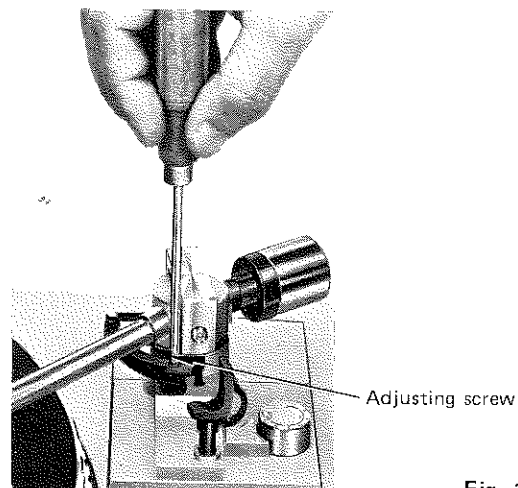

Fig. 12

8-(4) Headshell mounting Angle Adjustment (Fig. 13)

When the headshell is locked into the end of the tonearm, the stylus in some cartridges may still not be tangential (90°) to the platter. If such is the case, loosen the locking screws on the lower side of the tonearm using a small screwdriver (as shown) and move the headshell to adjust the stylus at a right angle (90°) to the platter. Measurement by eye is sufficient.

After adjustment be sure to tighten the locking screws firmly.

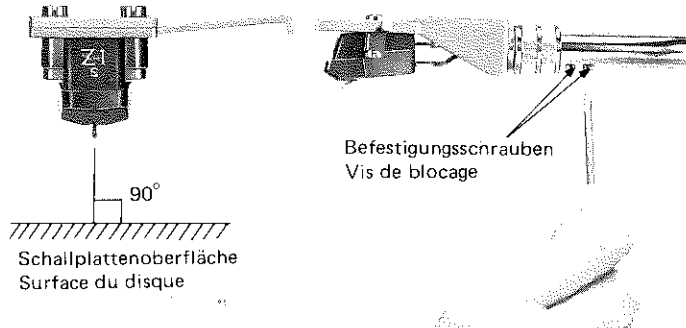

Fig. 13

8-(5) Tracking Force Adjustment

1. Set the anti-skating knob to the "0" mark on the dial.
2. Place an unwarped disc onto the platter.
3. Remove the stylus cover from the stylus.
4. Release the tonearm clamp.
5. Turn the counterweight until the tonearm is balanced.
6. Stop turning the counterweight when the stylus tip is almost touching the disc surface.
7. Return the tonearm to the rest and clamp it.
8. Hold the counterweight at the adjusted position and turn the tracking force dial until the "0" mark is aligned with the index line on the tonearm weight shaft. Turn the counterweight in the \textcircled{A} direction until the "1.75" mark on the dial is aligned with the index line for the model preparing cartridge Z-1S.

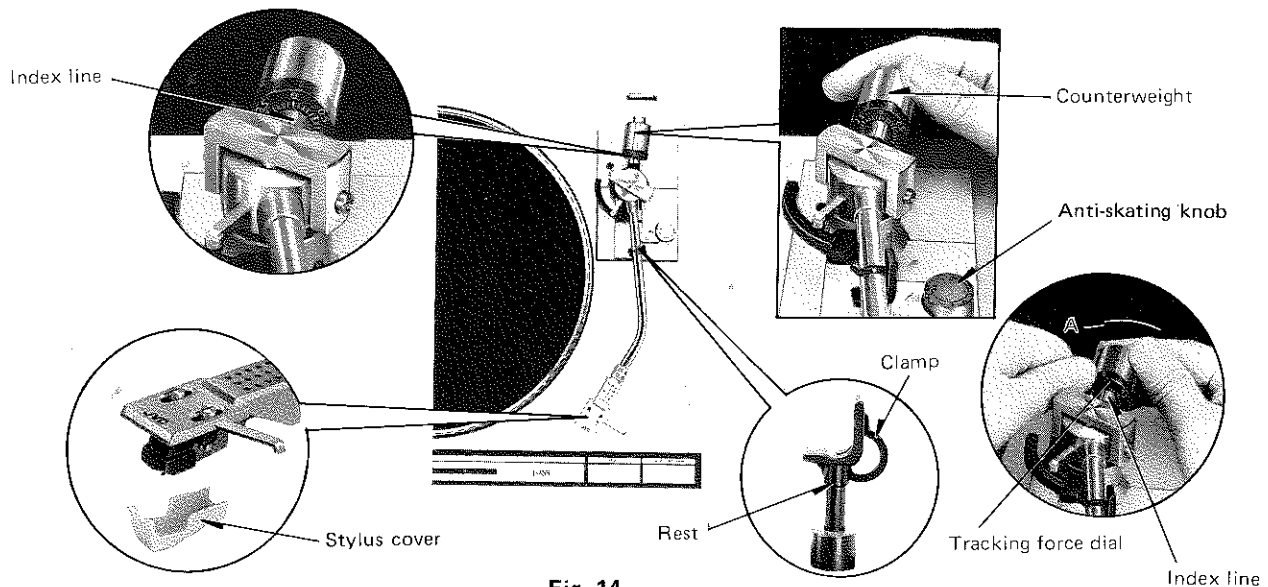

Fig. 14

8-(6) Auto-return (Lead-out) Adjustment

When the Tonearm has been replaced or if auto-return functions early or late, adjust as shown in Fig. 15.

- When change cycle starts too late, turn the screw counterclockwise with a screwdriver.
- When change cycle starts too early, turn the screw clockwise.

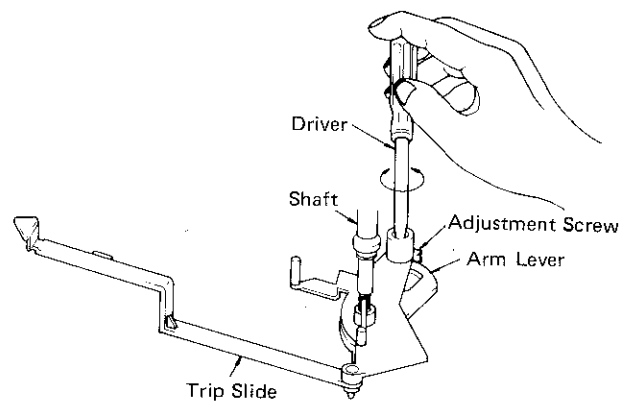

Fig. 15

Servomotor Control Section

8-(7) Speed Adjustment

1. Set the speed select switch to the 33-1/3 position and confirm that the 33-1/3 pilot lamp is lighting.
2. Turn the PITCH CONTROL knob to the center position (10k Ω /2).
3. Adjust VR1 (4.7k Ω) (see P. 15) so that the strobe pattern around the platter appear to be stationary.
4. Confirm that the strobe pattern appears to move at the same speed (approx.) with the PITCH CONTROL knob turned to the MAX and MIN positions.
5. In this condition, if the speed select switch is set to 45 position with the PITCH CONTROL knob set to the center position, the strobe pattern will appear to be stationary. (Speed adjustment for 33-1/3 rotation speed simultaneously makes the necessary adjustment for 45.)

9. Trouble Shooting

9-(1) Chart 1. "Platter does not rotate"

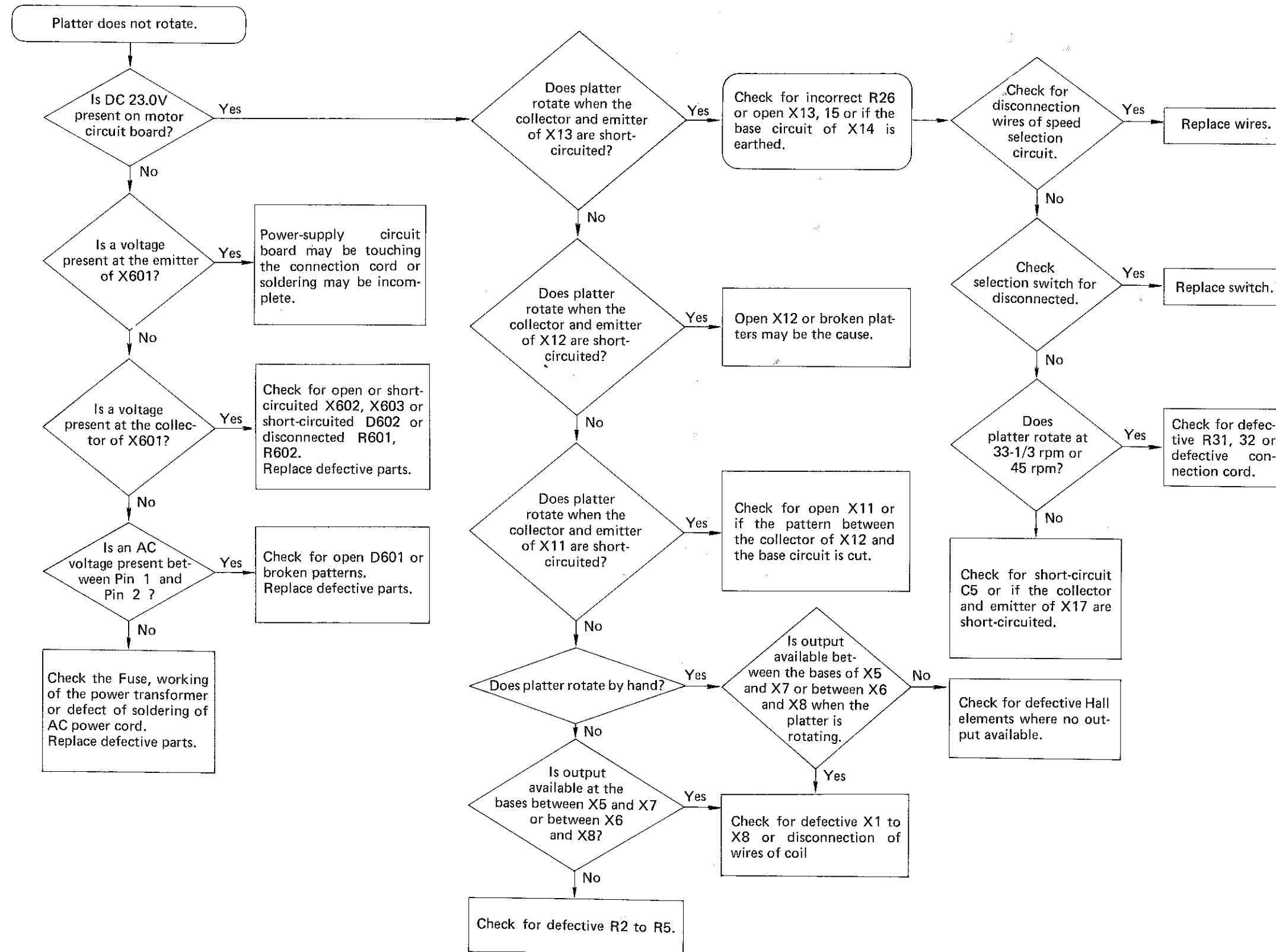

9-(2) Chart 2. "Platter rotates at a high speed"

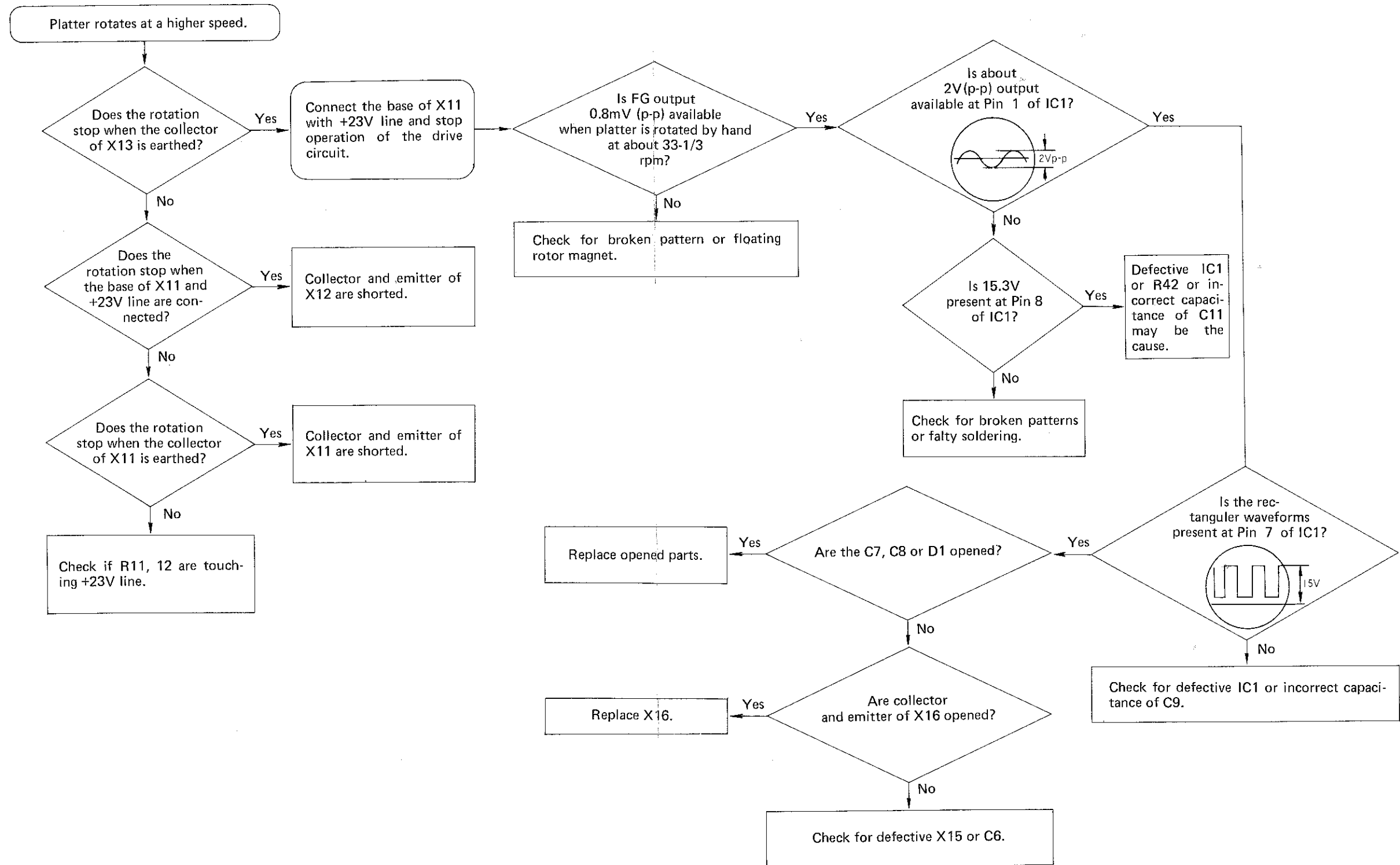

10. Lubrication

The direct drive motor employed in this unit does not require the lubrication.

11. Exploded Views and Parts List

11-(1) Tonearm Assembly

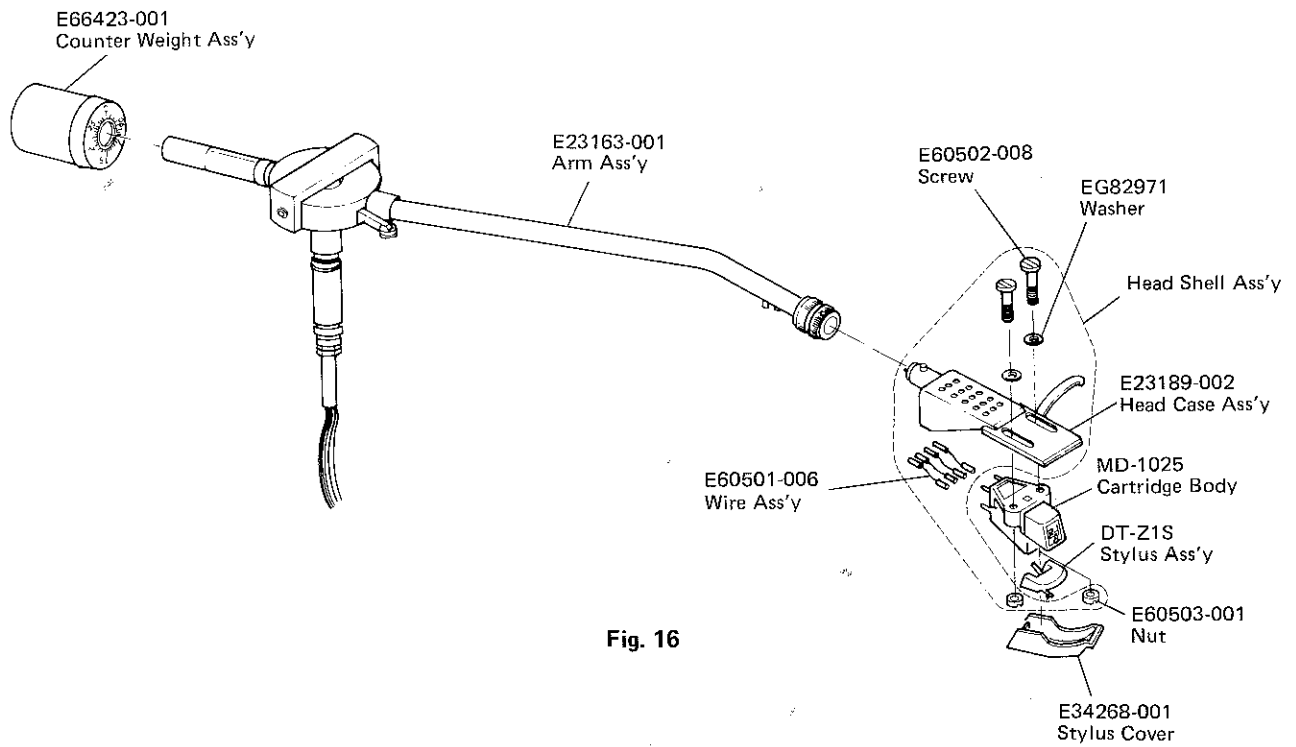

Fig. 16

11-(2) Cabinet and Mechanism Assembly and Parts List

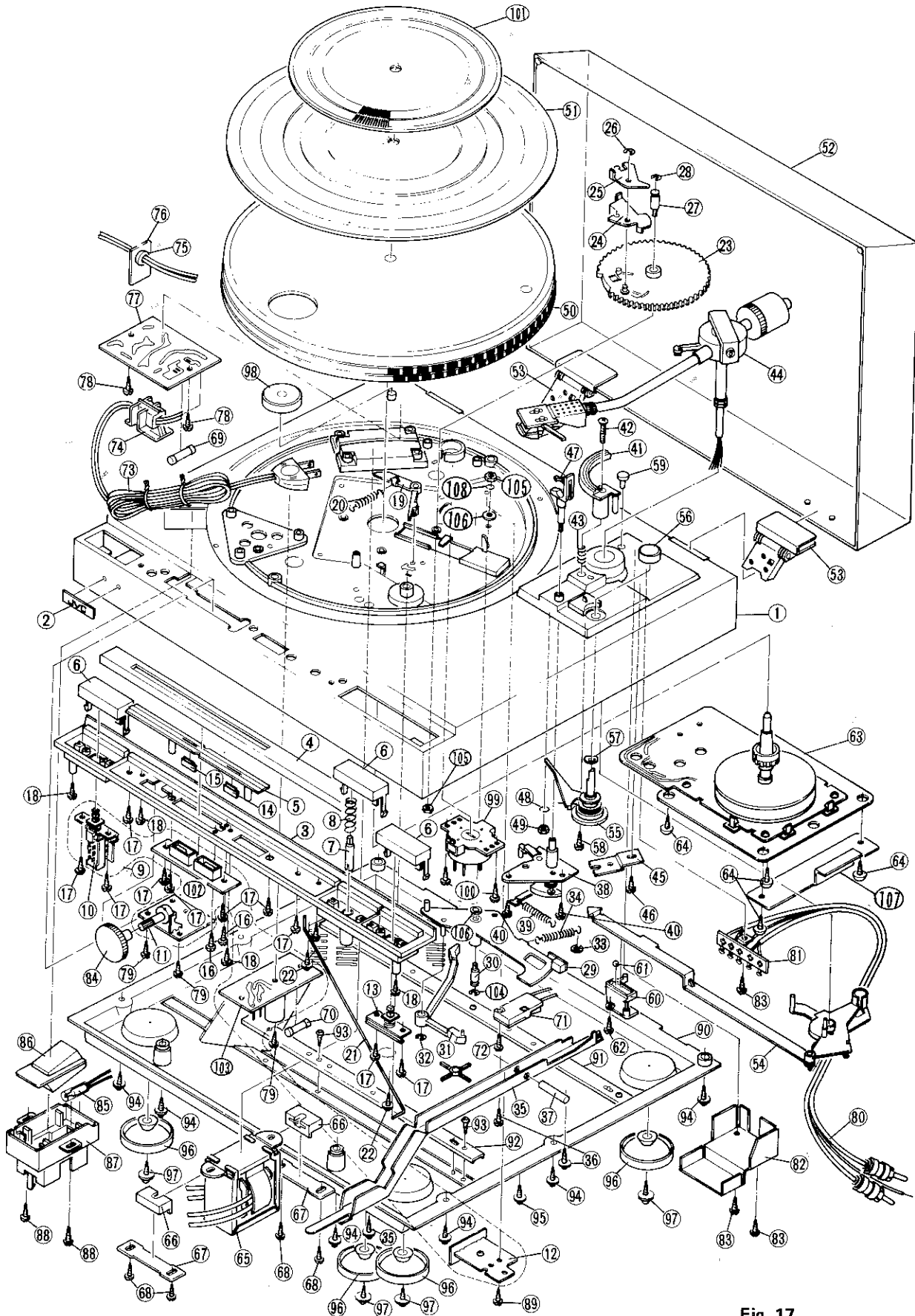



Fig. 17









Parts List

Item No.	Part Number	Description	Q'ty	Item No.	Part Number	Description	Q'ty
1	E10390-001	Cabinet	1	56	E300272-001	A.S. Knob	1
2	QXM2242-002	Mark (JVC)	1	57	E49602-002	Wave Washer	1
3	E23146-001	Front Panel	1	58	E65922-002	T. Screw	1
4	E300266-001	Sub Panel	1	59	See page 13	Mask Cap	1
5	E300267-001	C. Panel	1	60	E66373-001	Ball Holder	1
6	E300268-001	Knob	3	61	G41505-1	Steel Ball	1
7	E66350-001	Slider	1	62	E65921-002	T. Screw	1
8	E66351-001	Spring	1	63	MC941B	Motor	1
9	See page 13	C.Board Ass'y*	1	64	E65922-005	T. Screw	4
10	QSP0219-020	Push SW	1	65	See page 13	P. Transformer	1
11	QVF3A7B-014	V. RES	1	66	E61824-001	Cushion	2
12	E65674-002	Heat Sink	1	67	E65751-001	Trans Plate	2
13	E03820-002	Push SW.	1	68	E65921-003	T. Screw	4
14	E66352-001	Indicator	1	69	See page 13	Fuse	1
15	E66352-002	Indicator	1	70	"	Fuse	1
16	SBSB2606Z	T. Screw	2	71	"	Micro SW.	1
17	E65921-001	T. Screw	10	72	E65921-005	T. Screw	1
18	E65922-002	T. Screw	5	73	See page 13	Power Cord	1
19	E66353-001	Reject Lever	1	74	"	Cord Clamp	1
20	E49651-002	Reject Spring	1	75	"	Cord Stopper	1
21	E66355-001	Reject Rod	1	76	"	C.S. Plate	1
22	E65922-002	T. Screw	2	77	"	P.C.B. Ass'y	1
23	E21656-001	Gear	1	78	E65921-002	T. Screw	2
24	E49626-001	L. Trip Pawl	1	79	E65921-002	T. Screw	3
25	E49627-001	Eng. Pawl	1	80	E03724-002	Signal Cord	1
26	REE2000X	E. Ring	1	81	QML0002-051	Lug Strip Ass'y	1
27	E66633-001	Shaft	1	82	E66374-001	Shield Cover	1
28	REE5000	E Ring	1	83	E65921-002	T. Screw	3
29	E49613-010	R. Lever Ass'y	1	84	E61713-002	VR Knob	1
30	E66634-001	Stud	1	85	See page 13	Neon Lamp	1
31	E65249-001	SW. Lever	1	86	E66406-001	Prism	1
32	REE3000X	E. Ring	1	87	E300361-001	Lamp Holder	1
33	G4942-4	Speed Nut	1	88	E65921-002	T. Screw	2
34	E65251-001	Spring	1	89	SBSB3008Z	T. Screw	1
35	E300269-002	C. Lever Ass'y	1	90	E10389-001	Bottom Board	1
36	E65922-002	T. Screw	2	91	E300249-001	Frame	1
37	E66359-001	Cueing Shaft	1	92	E300249-002	Frame	1
38	E66360-001	C. Base Ass'y	1	93	E65921-002	T. Screw	5
39	E49596-001	Spring	1	94	E65922-004	T. Screw	9
40	E65921-002	T. Screw	3	95	E65922-006	T. Screw	3
41	E66365-001	Elevator Ass'y	1	96	See page 13	Foot Ass'y	4
42	SSSP3016M	Screw	1	97	E65923-001	T. Screw	4
43	E49649-001	Spring	1	98	E66329-001	E.P Adaptor	1
44	See page 13	Tonearm Ass'y	1	99	See page 13	V. Selector	1
45	E65289-001	Stopper	1	100	E65921-002	T. Screw	2
46	E65921-002	T. Screw	1	101	E61136-002	Strobo Plate	1
47	E60982-002	Arm Rest Ass'y	1	102	_____	LED C.B. Ass'y *	1
48	WLS4000N	Washer	1	103	_____	Secondary C.B. Ass'y *	1
49	NTB4000BS	Nut	1	104	REE3000X	E. Ring	1
50	E23113-001	Platter	1	105	NTB3000	Nut	2
51	See page 13	Platter Cover	1	106	Q03091-105	Washer	2
52	E10299-001	D. Cover Ass'y	1	107	E66655-002	Bracket	1
53	EG30133-001	Hinge Ass'y	2	108	WLS3000	Washer	1
54	E300271-001	Arm Lever Ass'y	1				
55	E66369-001	A.S. Lever Ass'y	1				

NOTE:  - SAFETY PARTS

* - These parts are not supplied separately.

11-(3) Parts List with Specified number for Designated Areas

Description	U.S.A.	Canada	Europe	U.K.	Australia	U.S. Military Market and other countries	Item No.
TONARM ASS'Y	ARM-532	ARM-532	MP-303S	ARM-532	MP-303S	MP-303S	44
PLATTER COVER	E22719-002	E22719-002	E22719-001	E22719-001	E22719-001	E22719-001	51
POWER TRANSFORMER 	E03032-31G	E03032-31G	E03032-31H	E03032-31HBS	E03032-31H	E03032-31J	65
FUSE 	QMF61U1-R30	QMF61U1-R30	QMF51A2-R125	QMF51A2-R125BS	QMF51A2-R125	QMF61U1-R30	69
FUSE 	QMF61U1-R50	QMF61U1-R50	QMF51A2-R50	QMF51A2-R50	QMF51A2-R50	QMF61U1-R50	70
MICRO SWITCH 	S9-031M	S9-031M	S9-033M	S9-033MBS	S9-033M	S9-031M	71
POWER CORD 	QMP1200-200	QMP1200-200	QMP3900-200	QMP9017-008BS	QMP2560-244	QMP7600-250	73
CORD CLAMP	_____	_____	A37897	A37897	A37897	A37897	74
CORD STOPPER	QHS3876-162	QHS3876-162	_____	_____	_____	_____	75
C.S. PLATE	E65465-001	E65465-001	_____	_____	_____	_____	76
P.C. BOARD ASS'Y 	TPS-206Q	TPS-206R	TPS-206T	TPS-206VBS	TPS-206U	TPS-206S	77
C. BOARD ASS'Y 	TPS-246A	TPS-246A	TPS-246B	TPS-246BBS	TPS-246B	TPS-246A	9
FOOT ASS'Y	E35857-003	E35857-003	E35857-005	E35857-005	E35857-005	E35857-005	96
VOLTAGE SELECTOR 	_____	_____	_____	_____	_____	QSR0085-001	99
MASK CAP	E65395-001	E65395-001	_____	_____	_____	_____	59
NEON LAMP	QLN3104-101	QLN3104-101	QLN3104-101	QLN3104-101	QLN3104-101	QLN3104-102	85

NOTE:  SAFETY PARTS

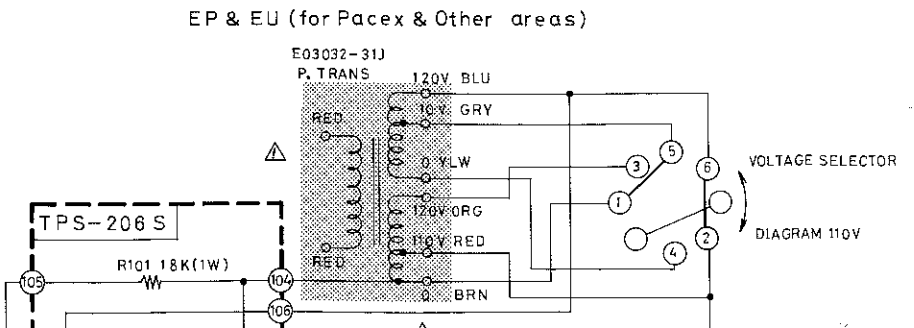
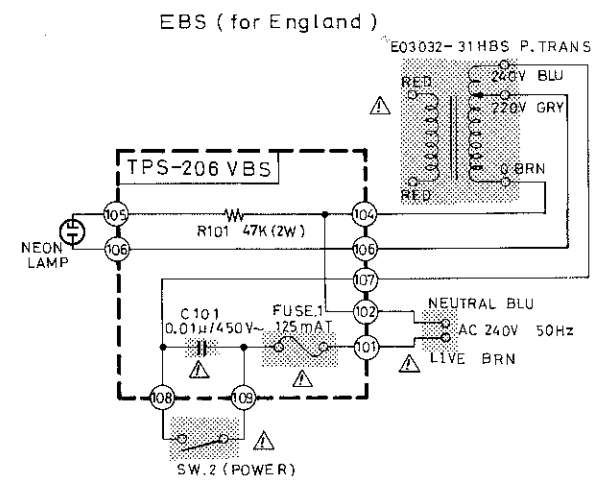
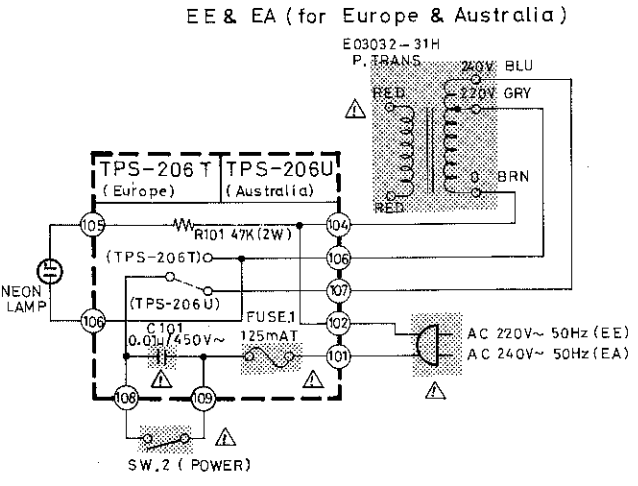
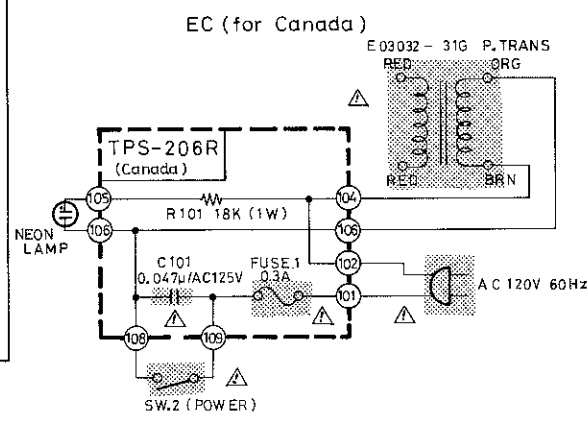
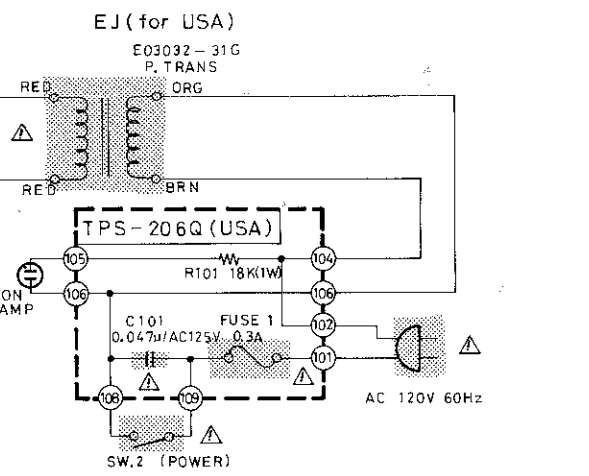
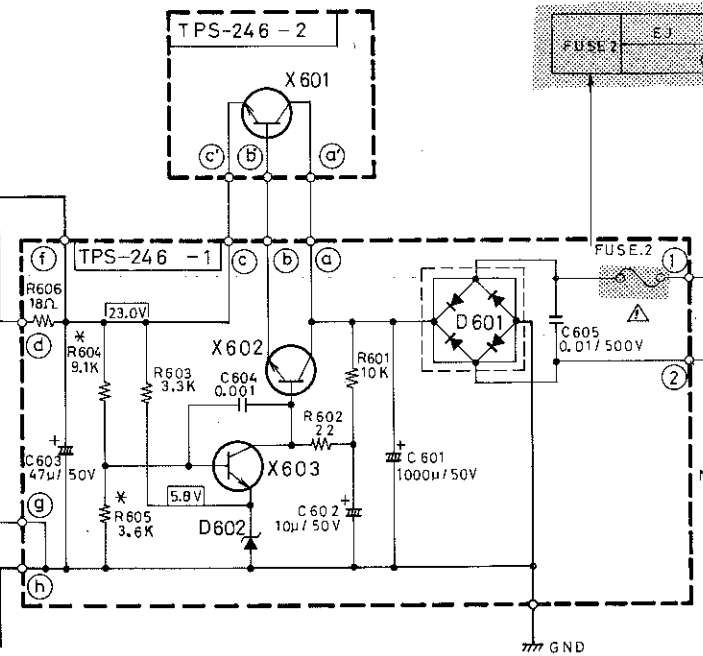
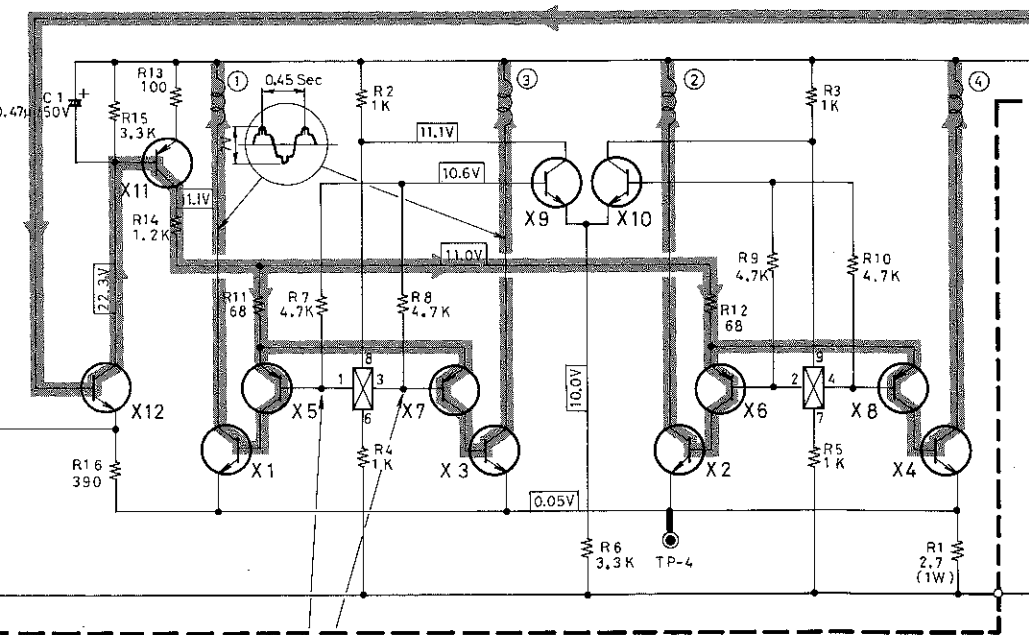
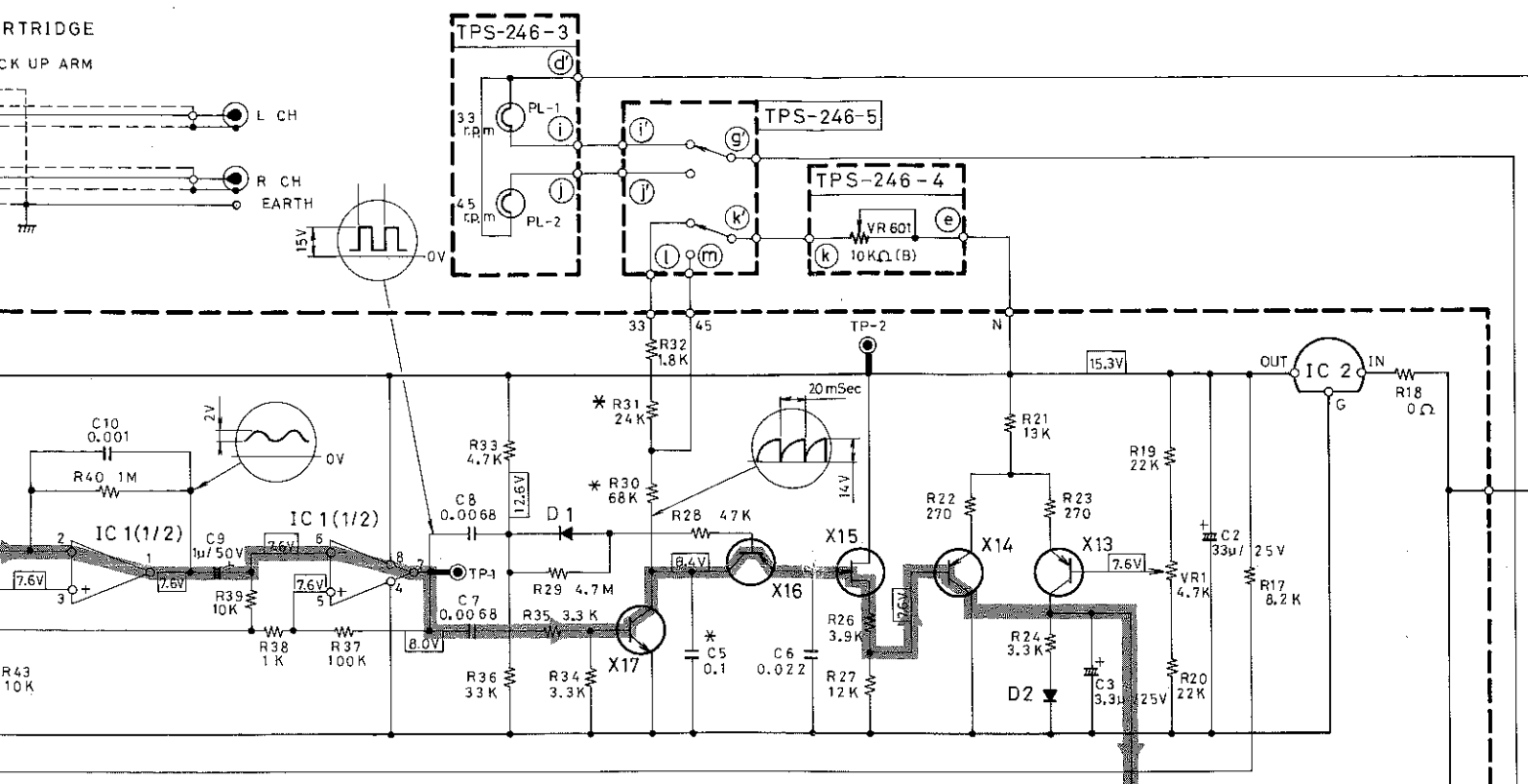
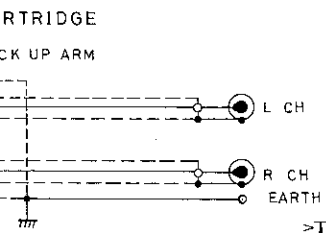

- 571
- 2SA733, 2SC945
- 2SK34
- 1SS53
- X5~X14, X16, X17
- X15
- D1, D2

- NJM4558D-D
- IC 1
- NJM78L15A
- IC 2
- 2SD571(K1, K2, L1, L2)
- X1~X4
- 2SA733(P, Q)
- X5~X8
- 2SA733(P, K)
- X11, X13, X14, X16
- 2SC945(P, N)
- X9, X10, X12, X17

Warning!

1. Be careful not to allow metallic dust into...

1

2

3

12. L-A55 Schematic Diagram

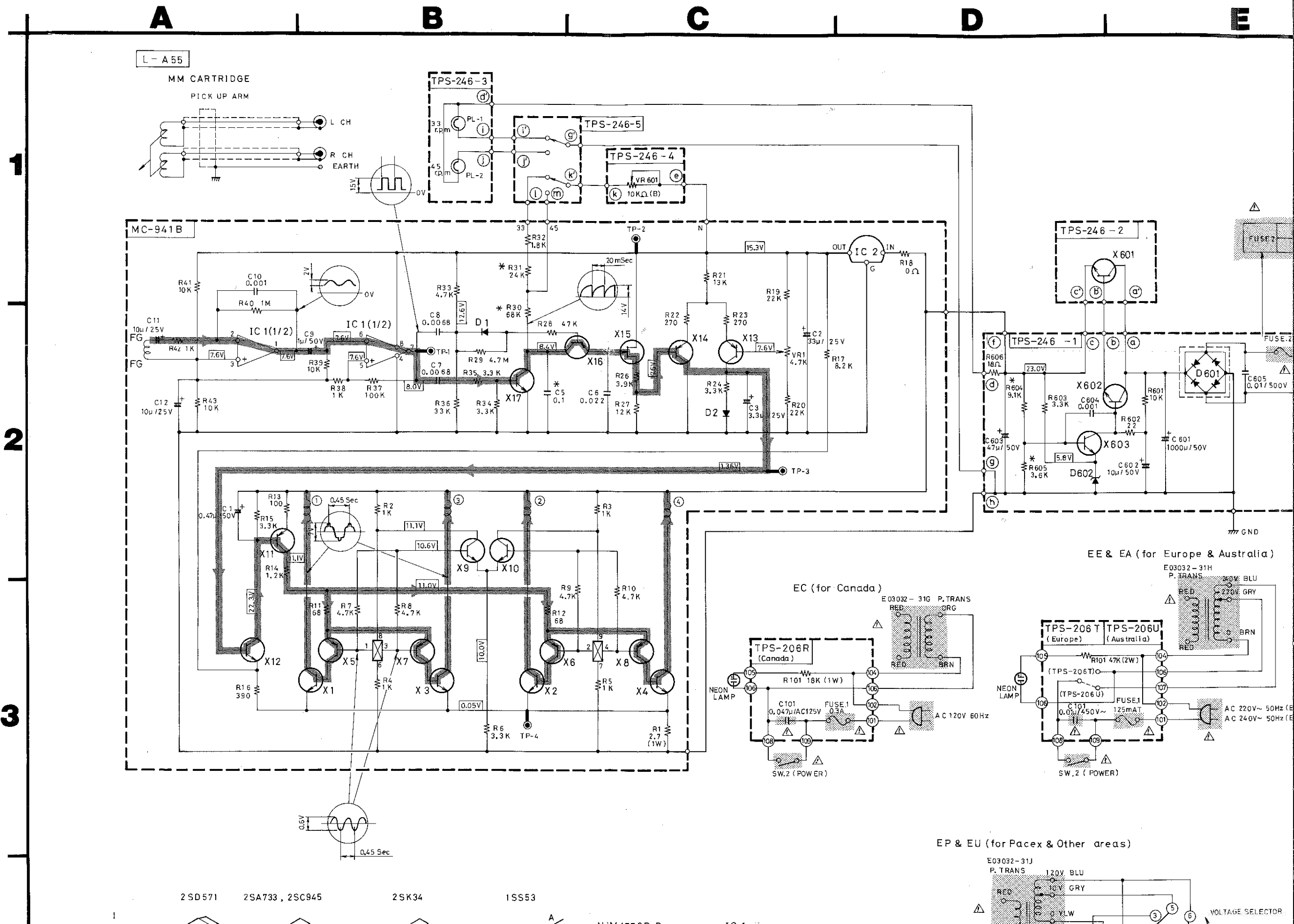

Printed Circuit Board Ass'y

A B C D E F

13-(1) MC-941B Printed Circuit Board Ass'y

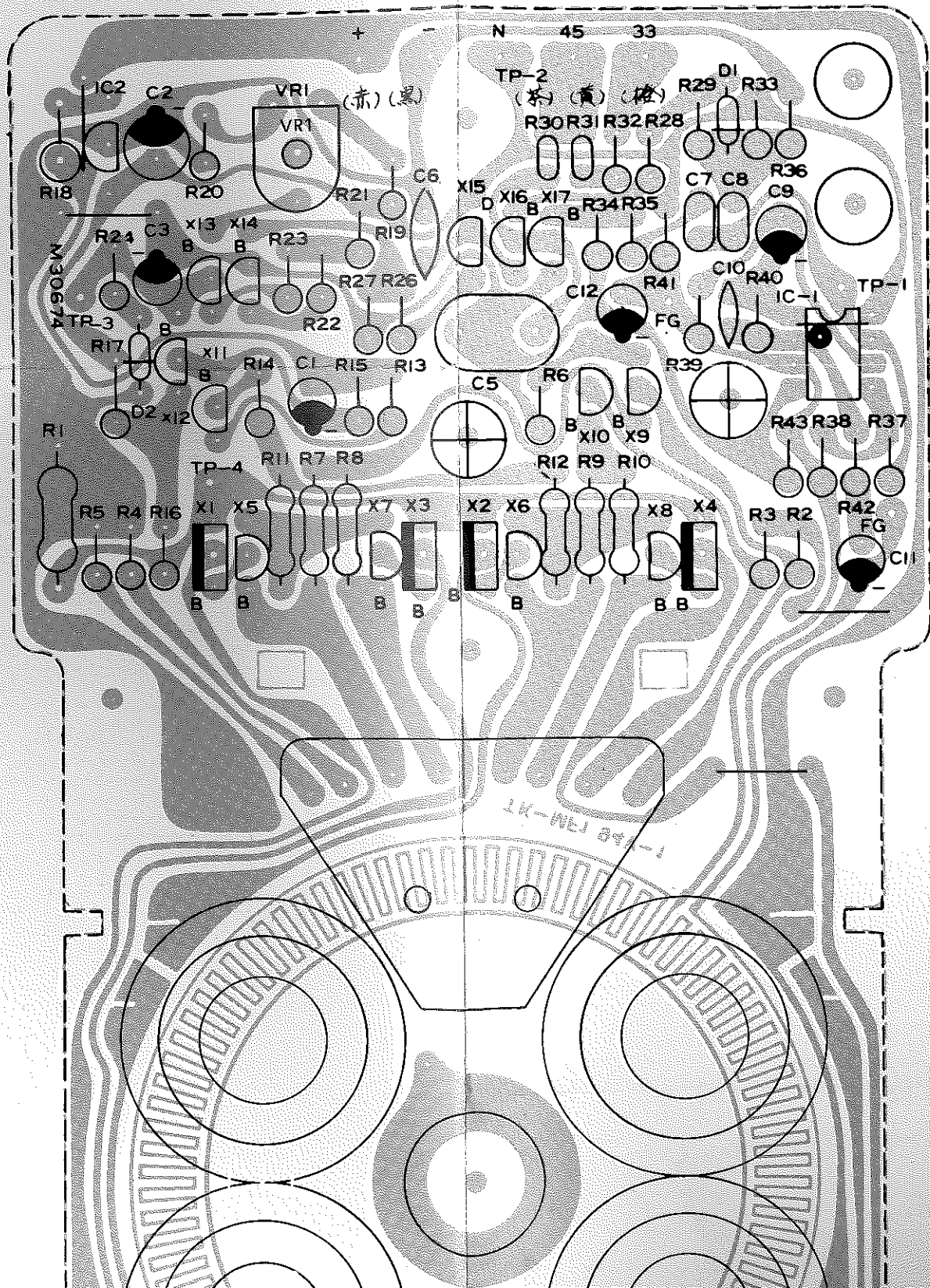

13-(2) TPS-246 Printed Circuit Board Ass'y

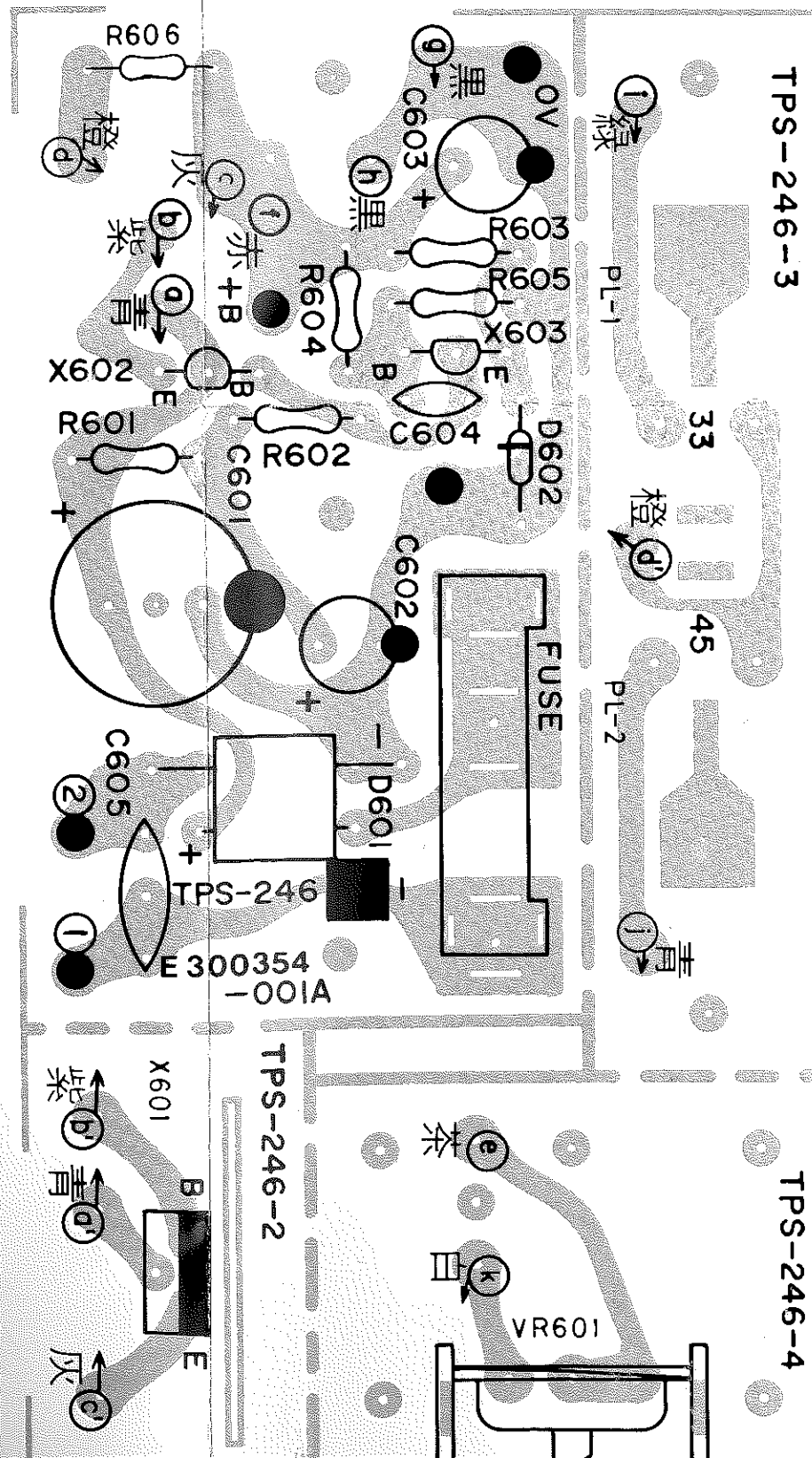

13-(3) MC-941B Parts List

Transistors

No.	Parts Number	Rating		Description	Maker
		Pc	fT		
X1	2SD571 (K1, K2, L1, L2)	800mW	110MHz	Silicon	NEC
X2	" "	"	"	"	"
X3	" "	"	"	"	"
X4	" "	"	"	"	"
X5	2SA733 (P, Q)	250mW	180MHz	"	"
X6	" "	"	"	"	"
X7	" "	"	"	"	"
X8	" "	"	"	"	"
X9	2SC945 (P, K)	250mW	250MHz	"	"
X10	" "	"	"	"	"
X11	2SA733 (P, K)	250mW	180MHz	"	"
X12	2SC945 (P, K)	250mW	250MHz	"	"
X13	2SA733 (P, K)	250mW	180MHz	"	"
X14	" "	"	"	"	"
X15	2SK34C	150mW	100MHz	"	Mitsubishi
X16	2SA733 (P, K)	250mW	180MHz	"	NEC
X17	2SC945 (P, K)	250mW	250MHz	"	"

Integrated Circuits

No.	Parts Number	Rating	Description	Maker
IC1	NJM4558D-D		IC	Shin Nihon Musen
IC2	NJM78L15A		"	"

Diodes

No.	Parts Number	Rating	Description	Maker
D1	1SS53		Silicon	N.E.C.
D2	"		"	"

Capacitors

No.	Parts Number	Rating		Description
C1	QET41HR-105	1 μ F	DC50V	Electrolytic
C2	QET41ER-336	33 μ F	DC25V	"
C3	QET41ER-335	3.3 μ F	"	"
C5	AWS104J-50	0.1 μ F	DC50V	Mylar
C6	QCF11HP-223	0.022 μ F	"	Ceramic
C7	QFM41HK-682	6800pF	"	Mylar
C8	"	"	"	"
C9	QET41HR-105	1 μ F	"	Electrolytic
C10	QCY41HK-102	1000pF	"	Ceramic
C11	QET41ER-106	10 μ F	DC25V	Electrolytic
C12	"	"	"	"

Resistors

No.	Parts Number	Rating		Description
R1	QRX016J-2R7	2.7Ω	1W	Metalized Film
R2	QRD143J-102	1kΩ	1/4W	Carbon
R3	"	"	"	"
R4	"	"	"	"
R5	"	"	"	"
R6	QRD143J-332	3.3kΩ	"	"
R7	QRD141J-472	4.7kΩ	"	"
R8	"	"	"	"
R9	"	"	"	"
R10	"	"	"	"
R11	QRD141J-680	68Ω	"	"
R12	"	"	"	"
R13	QRD143J-101	100Ω	"	"
R14	QRD143J-122	1.2kΩ	"	"
R15	QRD143J-332	3.3kΩ	"	"
R16	QRD143J-391	390Ω	"	"
R17	QRD143J-822	8.2kΩ	"	"
R18	QRD141J-0R0	0Ω	"	"
R19	QRD143J-223	22kΩ	"	"
R20	"	"	"	"
R21	QRD143J-133	13kΩ	"	"
R22	QRD143J-271	270Ω	"	"
R23	"	"	"	"
R24	QRD143J-332	3.3kΩ	"	"
R26	QRD143J-392	3.9kΩ	"	"
R27	QRD143J-123	12kΩ	"	"
R28	QRD143J-473	47kΩ	"	"
R29	QRD143J-475	4.7MΩ	"	"
R30	RE35YQ-68KF	68kΩ	"	Metalized Film
R31	RE35YQ-24KF	24kΩ	"	"
R32	QRD143J-182	1.8kΩ	"	Carbon
R33	QRD143J-472	4.7kΩ	"	"
R34	QRD143J-332	3.3kΩ	"	"
R35	"	"	"	"
R36	QRD143J-333	33kΩ	"	"
R37	QRD143J-104	100kΩ	"	"
R38	QRD143J-102	1kΩ	"	"
R39	QRD143J-103	10kΩ	"	"
R40	QRD143J-105	1MΩ	"	"
R41	QRD143J-103	10kΩ	"	"
R42	QRD143J-102	1kΩ	"	"
R43	QRD143J-103	10kΩ	"	"
VR1	RVAV413-472	4.7kΩ		Variable

13-(4) TPS-246 Parts List

Transistors

Item No.	Parts Number	Rating		Description	Maker
		Pc	ft		
X601	2SD325 (D, E)	10W	8MHz	Silicon	NEC
X602	2SC945 (P, Q)	250mW	250MHz	"	"
X603	2SC945 (P, Q)	250mW	250MHz	"	"

Diodes

Item No.	Parts Number	Rating	Description	Maker
D601	ESAB03-02A		Silicon	Fuji Denki
D602	RD5.6EB3		Zener	N.E.C

Capacitors

Item No.	Parts Number	Rating		Description
C601	QET51HR-108E	1000 μ F	DC50V	Electrolytic
C602	QET51HR-106	10 μ F	"	"
C603	QET51HR-476	47 μ F	"	"
C604	QET21HP-102	1000pF	"	Ceramic
C605	QET22HP-103	0.01 μ F	DC500V	"

Resistors

Item No.	Parts Number	Rating		Description
R601	QRD148J-103S	10k Ω	1/4W	Carbon
R602	QRD149J-220S	22 Ω	"	Nonflammable
R603	QRD148J-332S	3.3k Ω	"	Carbon
R604	QRV144F-9101	9.1k Ω	"	Metalized Film
R605	QRV144F-3601	3.6k Ω	"	"
R606	QRD149J-180S	18 Ω	"	Nonflammable
VR601	QVF3A7B-014	10k Ω	"	Variable

Others

Item No.	Parts Number	Rating	Description
	E65674-002		Heat Sink
	QSP0219-020		Push Switch
	QLP3201-008		Lamp
	E66313-002		Lamp Cap
	E66313-003		"
	E66452-001		Lamp Cover
	E41541-21		Bushing

Others

No.	Description	U.S.A.	Canada	Europe	U.K.	Australia	U.S. Military Market and Other Countries
	Fuse clip 	E45524-002	E45524-002	E48965-002	E48965-002	E48965-002	E45524-002

13-(5) TPS-206 Printed Circuit Board Ass'y and Parts List

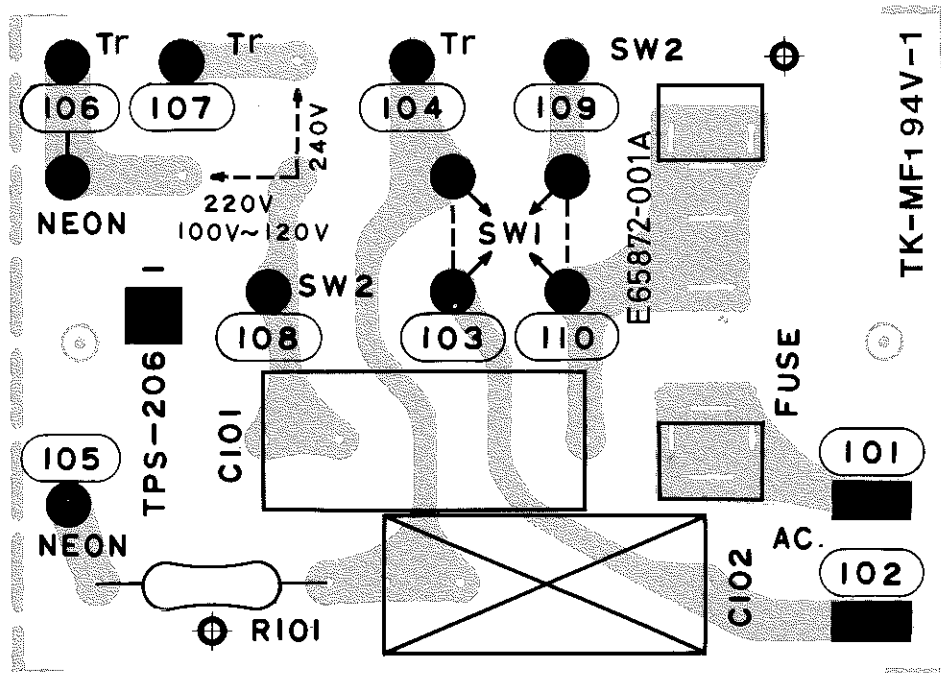



Fig. 18

No.	Description	U.S.A.	Canada	Europe	U.K.	Australia	U.S. Military Market and Other Countries
	Capacitor 	QFH72BM-473M	QFA72BM-473	QFZ9007-103	QFZ9007-103BS	QFZ9007-103	QFH53BM-103M
	Fuse Clip 	E45524-002	E45524-002	E48965-002	E48965-002	E48965-002	E45524-002
	Resistor	QRG017J-183S	QRG017J-183S	QRG027J-473	QRG027J-473	QRG027J-473	QRG017J-183S

14. Connection Diagram of TPS-246

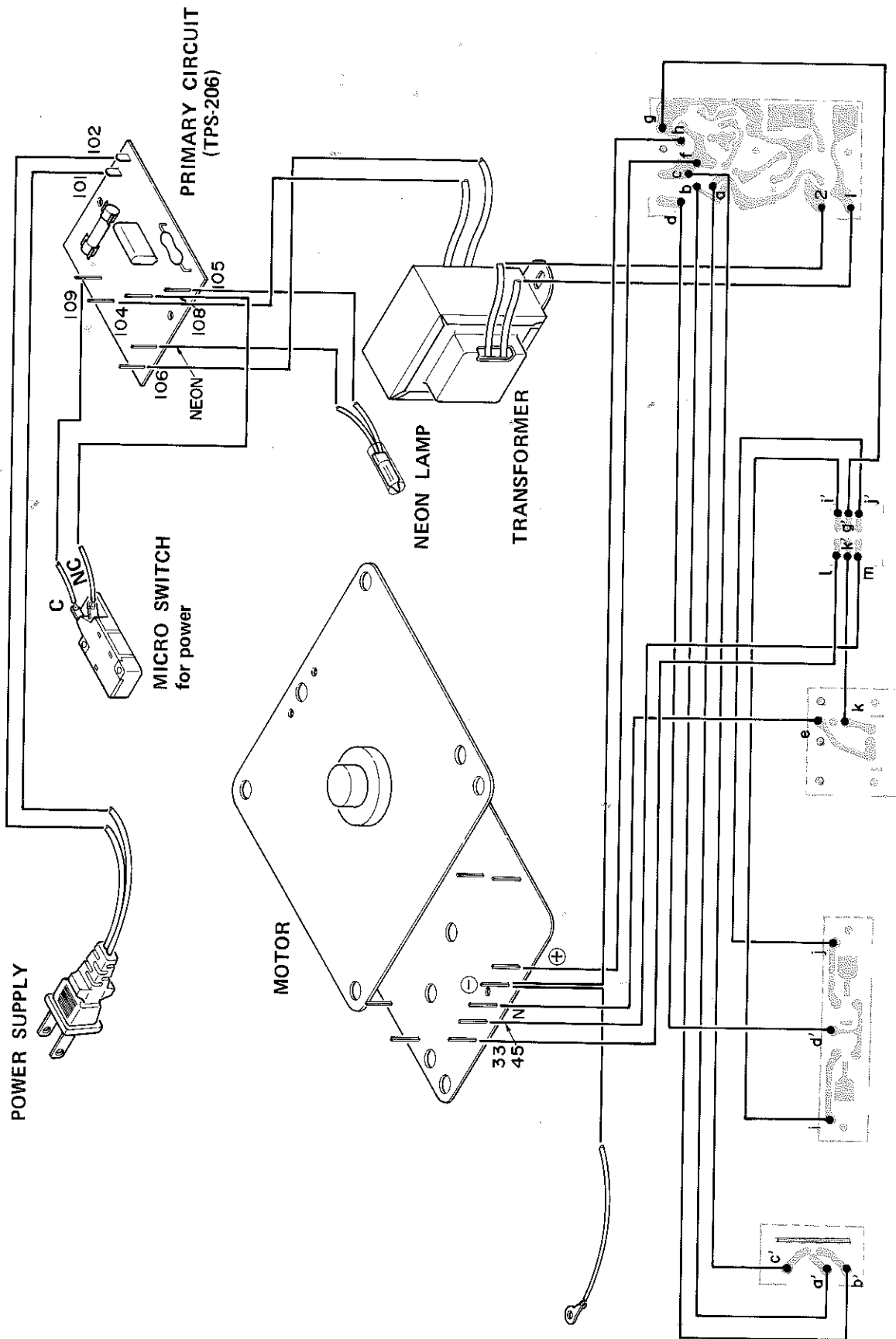

Fig. 19

15. Packing Materials and Part Number

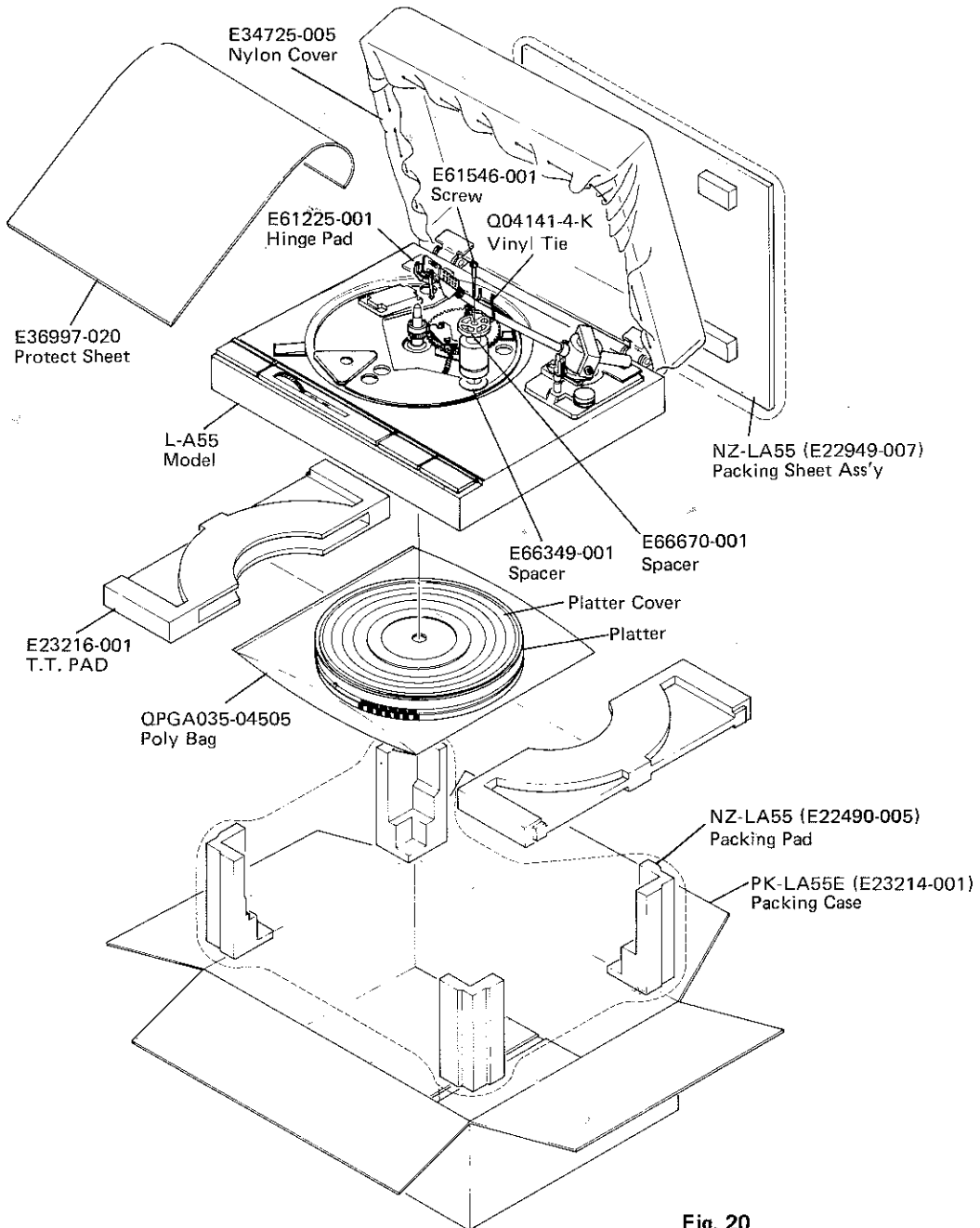

Fig. 20

16. Accessories List

Description	U.S.A.	Canada	Europe	U.K.	Australia	U.S. Military Market and other countries
INSTRUCTION BOOK	E30580-745A	E30580-745A	E30580-745A	E30580-754ABS	E30580-745A	E30580-745A
INSTRUCTION BOOK	_____	E30580-746A	E30580-746A	_____	_____	_____
WARRANTY CARD	BT20032B	BT20025B	_____	BT20013B	BT20029B	BT20032(P)
SERVICE PROCEDURE	BT20042	_____	_____	_____	_____	BT20042(P)
DO IT BETTER	BT20042	_____	_____	_____	_____	BT20042(P)
ENVELOPE	E41202-2	E41202-2	E41202-2	E41202-2	E41202-2	E41202-2
EP ADAPTER	E66329-001	E66329-001	E66329-001	E66329-001	E66329-001	E66329-001
SIEMENS PLUG	_____	_____	_____	_____	_____	E04056